

DD235

Version : A.003
Issue Date : 2008/02/21
File Name : SP-DD235-A.003.doc
Total Pages: 12

8x3-bit Constant Current LED Driver



新竹市科學園區展業一路9號7樓之1

SILICON TOUCH TECHNOLOGY INC.

9-7F-1, Prosperity Road I, Science Based Industrial Park,
Hsin-Chu, Taiwan 300, R.O.C.

Tel : 886-3-5645656 Fax : 886-3-5645626



DD235

8x3-bit Constant Current LED Driver

General Description

DD235 is a 24 channel constant-current sink driver specifically designed for LED decorating and backlighting applications. This chip incorporates shift registers, data latches, and constant current circuitry on the silicon CMOS process. The constant current values are set by three external resistors (Rext_R, Rext_G and Rext_B) separately. Each channel can provide a maximum current of 60mA. The three enable terminals (EN_R, EN_G and EN_B) supply dimming applications and control eight channels independently.

Features

- Maximum constant current output: 60mA
- Maximum output sustaining voltage: 17V
- Output enable terminal: 1MHz(max)
- Power supply voltage: 6V to 18V
- Over current protection
- Bit-to-bit skew : $\pm 6\%$ (max) Chip-to-chip skew : $\pm 10\%$ (max)

Applications

- LED decorative lamps or bulbs
- LED backlighting applications

Package Types

- QFN32 (with exposed pad)

Pin Connection (Bottom View)

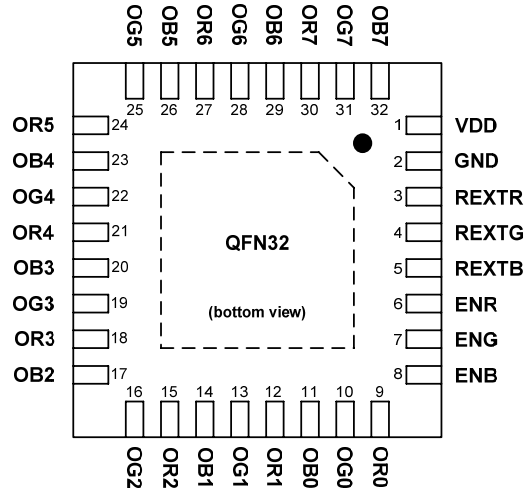

The package of QFN32

Pin Description

PIN NAME	FUNCTION
VDD [1]	Supply voltage terminal
GND [2]	Ground terminal
ENR [6]	Output enable terminals: ‘H’ for all outputs are active , ‘L’ for all outputs are turned off.
ENG [7]	
ENB [8]	
REXTR [3]	External resistors connected between REXT and GND for driver current setting
REXTG [4]	
REXTB [5]	
OR0~OR7 [9,12,15,18,21,24,27,30]	LED driver outputs
OG0~OG7 [10,13,16,19,22,25,28,31]	
OB0~OB7 [11,14,17,20,23,26,29,32]	

Block Diagram

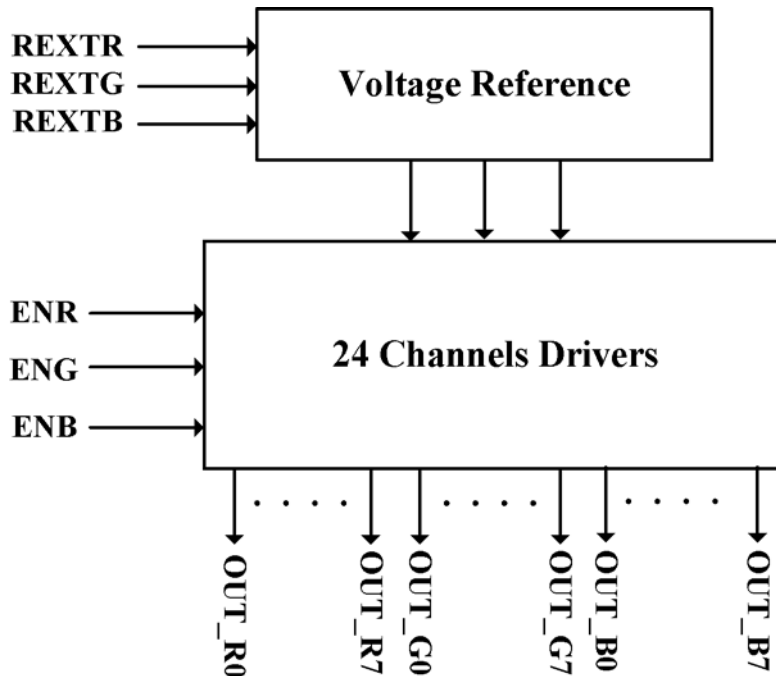

Equivalent Circuit of Inputs and Outputs

1. ENR, ENG, ENB terminals

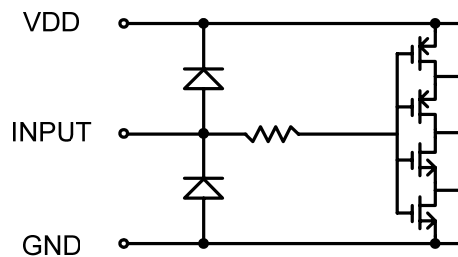



Maximum Ratings (Ta=25°C, Tj(max) = 120°C)

CHARACTERISTIC	SYMBOL	RATING	UNIT
Supply Voltage	VDD	18	V
Input Voltage	VIN	5	V
Output Current	IOOUT	60	mA
Output Voltage	VOOUT	17	V
Input Enable Frequency	FEN	1	MHz
GND Terminal Current	IGND	1500	mA
Power Dissipation (4 layer PCB)	PD	3.11 (QFN32 : Ta=25°C)	W
Thermal Resistance	Rth(j-a)	40.6 (QFN32)	°C/W
Operating Temperature	Top	-40 ~ 85	°C
Storage Temperature	Tstg	-55 ~ 150	°C

Recommended Operating Condition

CHARACTERISTIC	SYMBOL	CONDITION	MIN.	TYP.	MAX.	UNIT
Supply Voltage	VDD	—	6	—	18	V
Output Voltage	VOOUT	Driver On ^{*1}	1.0	—	0.5VDD	V
Output Voltage	VOOUT	Driver Off ^{*2}	—	—	17	
Output Current	IO	OUT	5	—	60	mA
Input Enable Voltage	VIH	VDD = 6V ~ 18V	3	—	VDD	V
	VIL		-0.3	—	1	
Input Enable Frequency	FEN	VEN>3V	DC	—	1	MHz

Electrical Characteristics (VDD = 6.0 V, Ta = 25°C unless otherwise noted)

CHARACTERISTIC	SYMBOL	CONDITION	MIN.	TYP.	MAX.	UNIT
Input Voltage "H" Level	VIH	VDD=6~18V	3	—	VDD	V
Input Voltage "L" Level	VIL		-0.3	—	1	
Output Leakage Current	IOL	VOH = 17 V VEN=0V	—	—	1.0	uA
Output Current Skew (Channel-to-Channel) ^{*1}	IOL1	VOOUT = 1.0 V Rrest = 5 KΩ	—	—	±6	%
Output Current Skew (Chip-to-Chip) ^{*2}	IOL2		±10	%		

^{*1} Notice that the power dissipation is limited to its package and ambient temperature.

^{*2} The driver output voltage including any overshoot stress has to be compliant with the maximum voltage (17V).

^{*1} Channel-to-channel skew is defined as the ratio between (any Iout – average Iout) and average Iout, where average Iout = (Imax + Imin) / 2.

^{*2} Chip-to-Chip skew is defined as the range into which any output current of any IC falls.



Output Voltage Regulation	% / V _{OUT}	R _{rext} = 5 KΩ V _{OUT} = 1 V ~ 3 V	—	±0.1	±0.5	% / V
Supply Voltage Regulation	% / V _{DD}	R _{rext} = 5 KΩ	—	±1	±4	
Supply Current ^{*3} V _{DD} =6V V _{DD} =12V V _{DD} =18V	I _{DD} (off)	R _{EXT} = OPEN, all outputs off	—	4.6 5.7 7.4	—	mA
	I _{DD} (off)	R _{EXT} =1.5KΩ(I _{out} =60mA), all outputs off	—	14.6 15.7 18.6	—	
	I _{DD} (on)	R _{EXT} =1.5KΩ(I _{out} =60mA), all outputs on	—	14.6 15.7 18.6	—	
	I _{DD} (off)	R _{EXT} = 5KΩ (I _{out} =21mA), all outputs off	—	4.8 5.9 7.7	—	
	I _{DD} (on)	R _{EXT} = 5KΩ (I _{out} =21mA), all outputs on	—	4.8 5.9 7.7	—	

Switching Characteristics (V_{DD} = 6.0V, T_a = 25°C unless otherwise noted)

CHARACTERISTIC		SYMBOL	CONDITION	MIN.	TYP.	MAX.	UNIT
Propagation Delay (‘L’ to ‘H’)	EN-to-OUT	tpLH	V _{IH} = V _{DD} V _{IL} = GND	—	40	—	ns
Propagation Delay (‘H’ to ‘L’)	EN-to-OUT	tpHL	R _{rext} = 4.17 KΩ V _L = 1.0 V	—	45	—	
Output Current Rise Time		tor	R _L = 0 Ω	—	15	—	
Output Current Fall Time		tof	C _L ^{*1} = 13 pF	—	8	—	
Output Delay Time (OUT _(n) -to-OUT _(n+1))		tod		—	0.5	—	

^{*3} IO excluded.

^{*1} CL means the probe capacitance of oscilloscope.

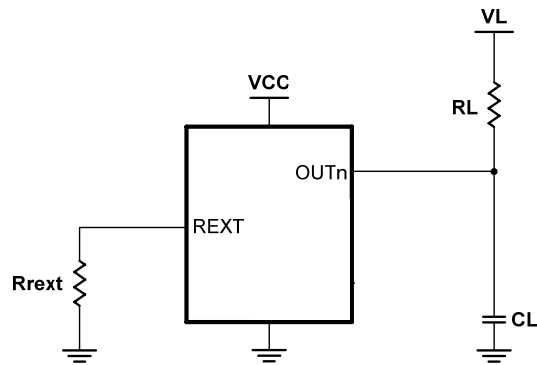

Switching Characteristics Test Circuit

Timing Diagram

1. \overline{EN} -OUT

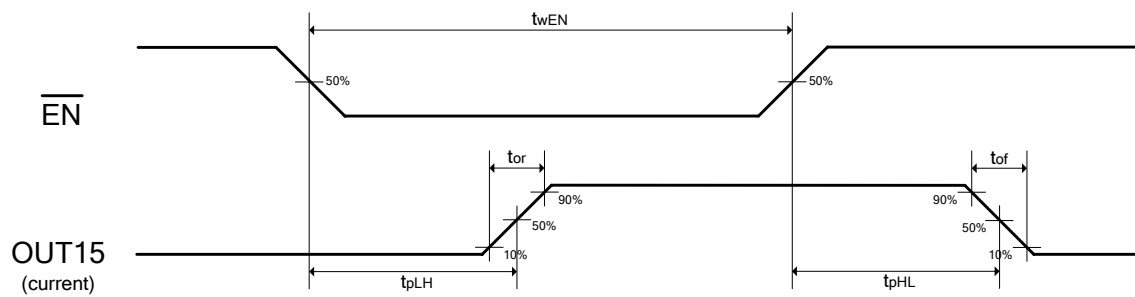

2. OUT_{n+1} - OUT_n

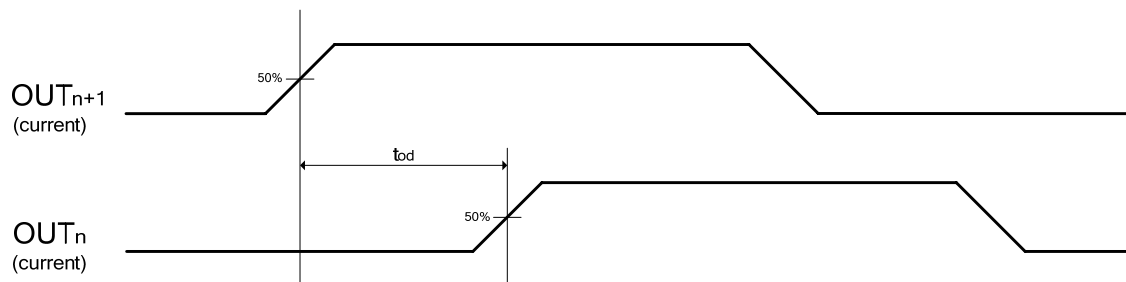

Constant-Current Output

Constant-current value of each output channel is set by an external resistor connected between the REXT pin and GND. Varying the resistor value can adjust the current scale ranging from 5mA to 60mA. The reference voltage of REXT terminal (V_{rext}) is approximately 1.1V. The output current value is calculated roughly by the following equation:

$$I_{out}(mA) \cong \frac{V_{rext}(V)}{R_{ext}(K\Omega)} \times M$$

I _{out} (mA)	5	10	20	30	40	50	60
M	101.4	99.5	97.1	94.6	92.1	89.5	83.1

Output current & R_{rext} value

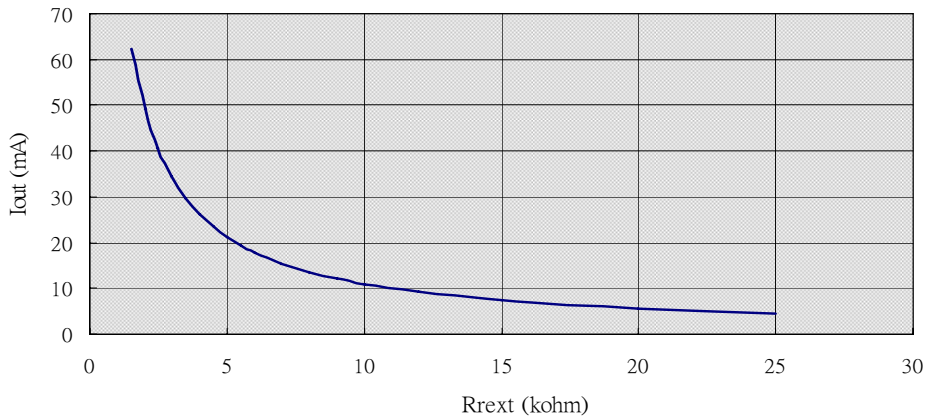

Output Current & Output Voltage Curve

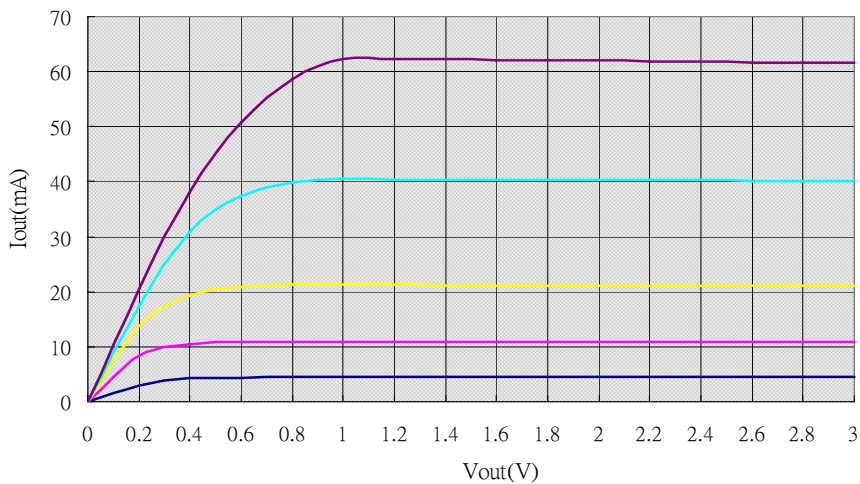

In order to obtain a good performance of constant-current output, a suitable output voltage is necessary. Users can get related information about the minimum output voltage above.

Thermal Shutdown

During operation, when the junction temperature of the IC will reach approximately above 180°C, it will cause the driver to shutdown all the outputs. Basically, the IC will cool down and return to the safe operating temperature which is approximately below 110°C. DM13C will restart all the outputs at the same time. Operation in the thermal situation for a long time may cause chip damage permanently.

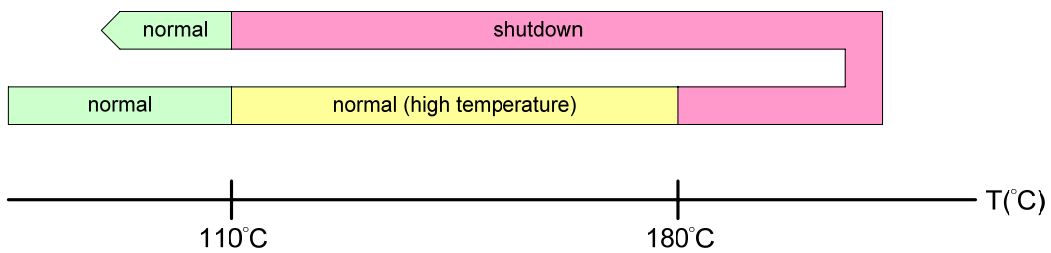

Relations between Thermal Shutdown and Junction Temperature

Typical Application

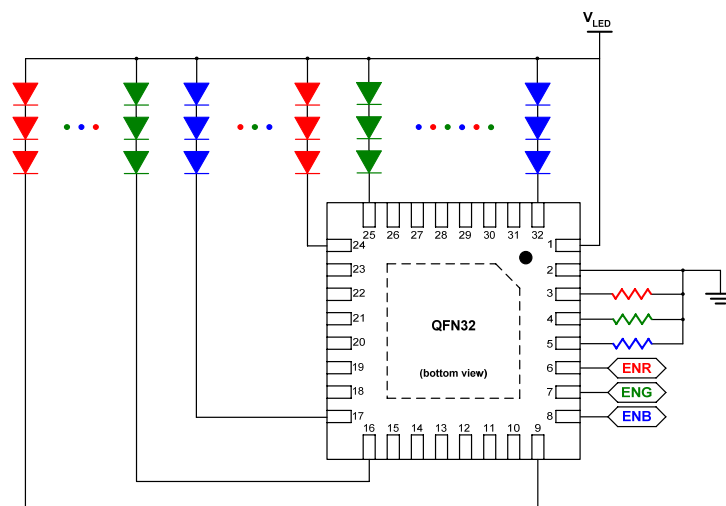

Power Dissipation

The power dissipation of a semiconductor chip is limited to its package and ambient temperature, in which the device requires the maximum output current calculated for given operating conditions. The maximum allowable power consumption can be calculated by the following equation:

$$Pd(max)(Watt) = \frac{Tj(junction\ temperature)(max)(\text{ }^{\circ}C) - Ta(ambient\ temperature)(\text{ }^{\circ}C)}{Rth(junction\text{-to}\text{-air\ thermal\ resistance})(\text{ }^{\circ}C/Watt)}$$

The relationship between power dissipation and operating temperature can be refer to the figure below:

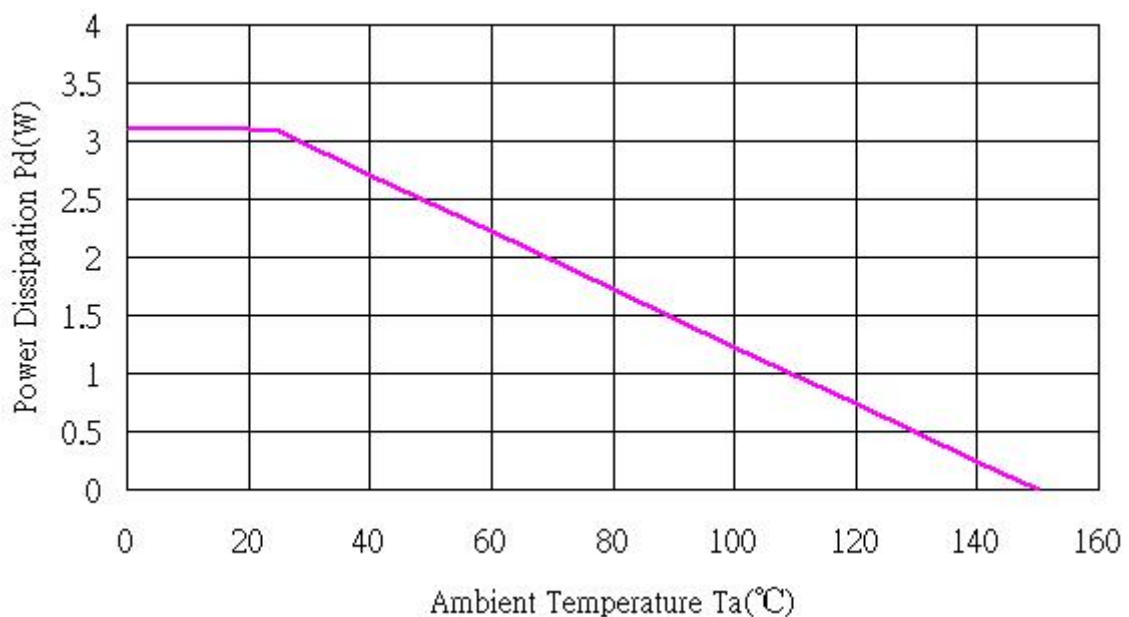

The power consumption of IC can be determined by the following equation and should be less than the maximum allowable power dissipation:

$$Pd(W) = Vcc(V) \times IdD(A) + Vout0 \times Iout0 \times Duty0 + \dots + Vout15 \times Iout15 \times Duty15 \leq Pd(max)(W)$$

Package Outline Dimension

QFN32

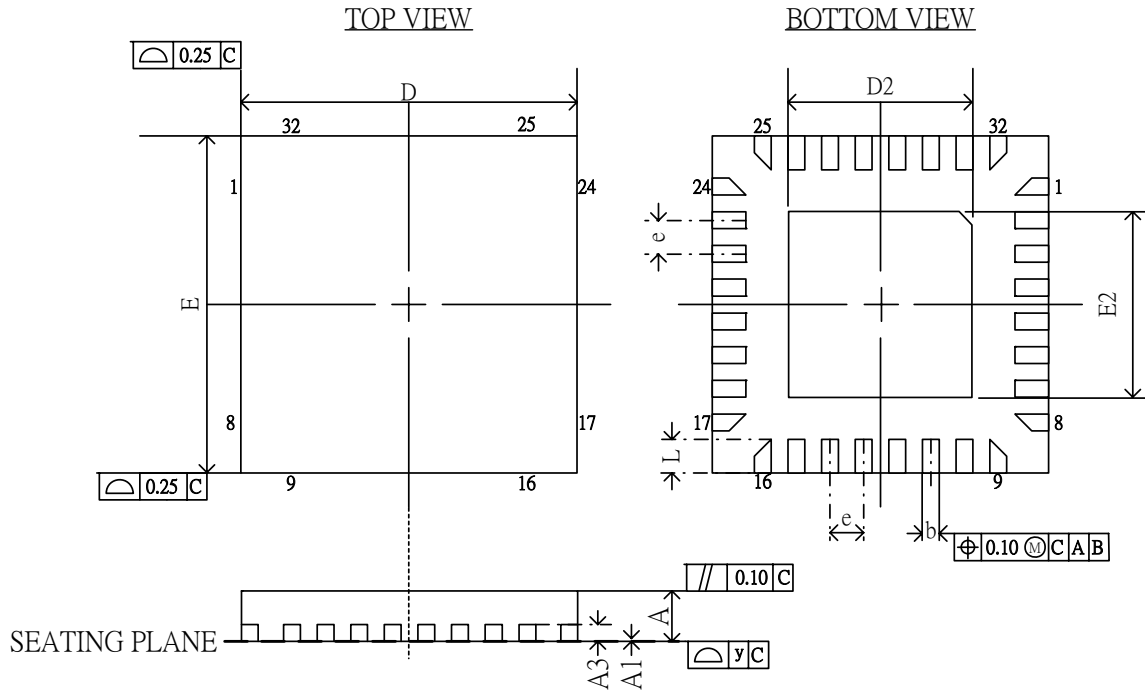

SYMBOLS	DIMENSIONS IN INCH		DIMENSIONS IN MM	
	MIN.	MAX.	MIN.	MAX.
A	0.028	0.031	0.70	0.80
A1	0	0.002	0	0.05
A3	0.010TYP.		0.25TYP.	
b	0.007	0.012	0.18	0.30
D	0.197TYP.		5.00TYP.	
D2	0.049	0.128	3	3.25
E	0.197TYP.		5.00TYP.	
E2	0.049	0.128	3	3.25
e	0.020		0.50TYP.	
L	0.012	0.020	0.30	0.50
y	0.004TYP.		0.10TYP.	

Note: 1. DIMENSIONING AND TOLERANCING CONFORM TO ASME Y145.5M-1994.

2. REFER TO JEDEC STD. MO-220 WHHD-2 ISSUE A



The products listed herein are designed for ordinary electronic applications, such as electrical appliances, audio-visual equipment, communications devices and so on. Hence, it is advisable that the devices should not be used in medical instruments, surgical implants, aerospace machinery, nuclear power control systems, disaster/crime-prevention equipment and the like. Misusing those products may directly or indirectly endanger human life, or cause injury and property loss.

Silicon Touch Technology, Inc. will not take any responsibilities regarding the misuse of the products mentioned above. Anyone who purchases any products described herein with the above-mentioned intention or with such misused applications should accept full responsibility and indemnify. Silicon Touch Technology, Inc. and its distributors and all their officers and employees shall defend jointly and severally against any and all claims and litigation and all damages, cost and expenses associated with such intention and manipulation.