

CURRENT MODE PWM CONTROLLER

DESCRIPTION

SD4870 is a current mode PWM controller IC for high performance, low standby power offline flyback converter application.

In no load or light load condition, the IC operates in Light Load Mode to reduce switching loss and improve efficiency.

Large value startup resistor could be used in the startup circuit to minimize the standby current because of low startup current.

SD4870 offers complete protection functions including cycle-by-cycle over current protection, over load protection, VDD voltage over voltage and under voltage protection, etc.

Excellent EMI performance is achieved with frequency shuffling technique and soft switching control at the totem pole gate driver output.

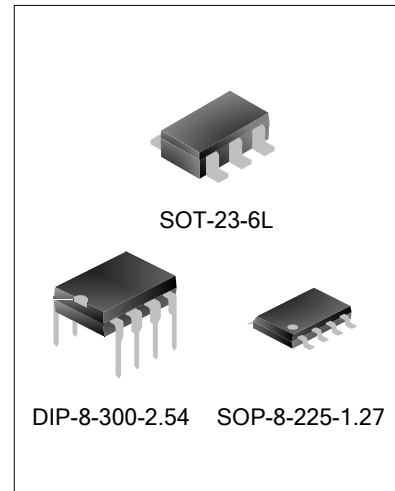

FEATURES

- * Frequency shuffling to improve EMI performance
- * Light Load Mode for minimum standby power
- * External programmable switching frequency
- * 3uA low startup current
- * Internal LEB circuit
- * VDD over voltage and under voltage protection
- * Gate output maximum voltage clamp
- * Current limiting
- * Over load protection
- * SOT-23-6L/SOP8/DIP8 package

APPLICATIONS

- * Battery Chargers
- * Adapters
- * Set-Top Box Power Supplies

ORDERING INFORMATION

Part No.	Package	Marking	Material	Packing
SD4870TR	SOT-23-6L	4870	Pb free	Tape & Reel
SD4870A	DIP-8-300-2.54	SD4870A	Pb free	Tube
SD4870C	SOP-8-225-1.27	SD4870C	Pb free	Tube
SD4870CTR	SOP-8-225-1.27	SD4870C	Pb free	Tape & Reel

BLOCK DIAGRAM

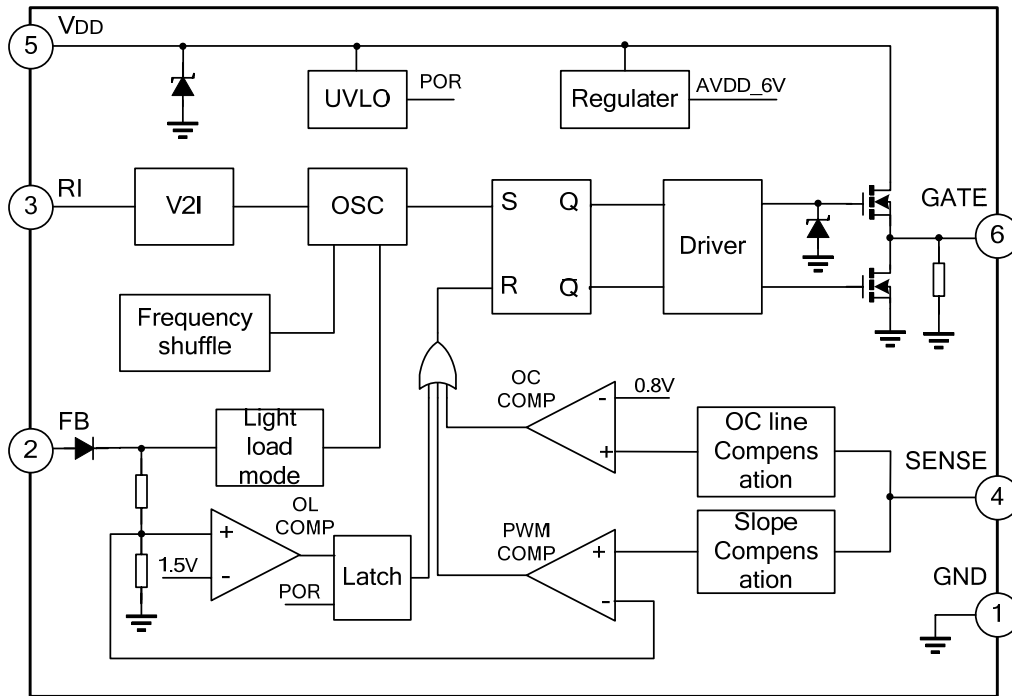

ABSOLUTE MAXIMUM RATINGS

Characteristics	Symbol	Rating	Unit
VDD Voltage	VVDD	25	V
FB Voltage	VFB	-0.3~6	V
SENSE Voltage	VSENSE	-0.3~6	V
RI Voltage	VRI	-0.3~6	V
Junction Temperature	T _j	-20~150	°C
Lead Temperature	T _L	260	°C
Storage Temperature	T _{stg}	-55~160	°C

ELECTRICAL CHARACTERISTICS (Unless otherwise specified, $T_{amb}=25^{\circ}C$)

Characteristics	Symbol	Test Condition	Min.	Typ.	Max.	Unit
VDD						
Startup Current	IVDD_ST	VDD=12 V, RI=100k Ω	--	3	20	μ A
Operation Current	IVDD	VDD=16V, VFB =3V, RI=100k Ω	--	2	--	mA
UVLO Threshold Voltage	VUVLO		13.3	14.3	15.3	V
UVLO Hysteresis Voltage	VUVLOH		--	6.3	--	V
VDD Clamp Voltage	VVDD_CLP	IVDD =10mA	--	21.5	--	V
Feedback						
PWM Gain	AVCS	$\Delta V_{FB} / \Delta V_{SENSE}$	--	2	--	V/V
FB Open Loop Voltage	VFB_OPEN		4.5	4.8	5	V
FB Short Circuit Current	IFB_SHORT	FB short connected to ground	0.8	1	1.2	mA
FB OL Threshold Voltage	VFB_OL		--	3.8	--	V
OL Debounce Time	T _{D_OL}			35	--	ms
FB Input Impedance	Z _{FB_IN}		4	6	--	k Ω
Maximum Duty Cycle	D _{MAX}	VDD=16V, RI=100k Ω VFB =3V, VSENSE =0V	--	75	--	%
Current Sense						
LEB Time	T _{LEB}	RI=100k Ω	--	300	--	ns
SENSE Input Impedance	Z _{SENSE_IN}		--	85	--	k Ω
OC Control Delay	T _{OC}		--	75	--	ns
OC Detection Threshold	V _{SENSE_OC}		0.7	0.75	0.8	V
Switching Frequency						
Oscillation Frequency	f _s	RI=100k Ω	60	65	70	kHz
Frequency Stability With VDD	Δf_{s_VDD}	VDD=12~25V, RI=100k Ω	--	5	--	%
RI External Resistance Range	R _{RI_RANGE}		50	100	150	k Ω
Light Load Mode Frequency	f _{s_LLM}		--	22	--	kHz
Frequency Shuffling Range	Δf_{s_SHUF}	RI=100k Ω	-3	--	3	%
Gate Driver						
Output Low Level	V _{OL}	VDD=16V, I _O =-20mA	--	--	0.8	V
Output High Level	V _{OH}	VDD=16V, I _O =20mA	10	--	--	V
Output Clamp Voltage Level	V _{OH_CLAMP}		--	13	--	V
Output Rising Time	T _R	VDD=16V, C _L =1nF	--	220	--	ns
Output Falling Time	T _F	VDD=16V, C _L =1nF	--	70	--	ns

PIN CONFIGURATION

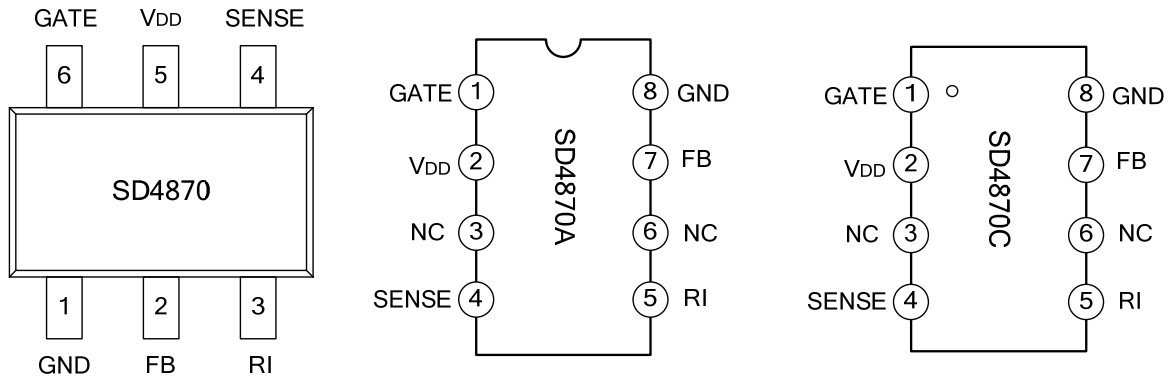

PIN DESCRIPTIONS

Pin No.		Pin Name	I/O	Description
SD4870	SD4870A SD4870C			
1	8	GND	--	Ground.
2	7	FB	I	Feedback input pin.
3	5	RI	I/O	Oscillator frequency setting pin. A resistor connected between RI and GND.
4	4	SENSE	I	Switch current sense input pin.
5	2	VDD	--	Power supply pin.
6	1	GATE	O	Gate driver output pin.
	3,6	NC	--	Not connect

FUNCTION DESCRIPTIONS

SD4870 is a current mode PWM controller used in applications for offline flyback converter. The description of functions is as follows.

Startup Control

Startup current of SD4870 is very low so that IC could start up quickly. A large value startup resistor can be used in startup circuit to minimize standby power loss yet provides reliable startup in application.

A 2 M Ω , 1/8 W startup resistor is recommended in normal input range.

Frequency Shuffling Control

Frequency shuffling is used in SD4870 to improve EMI performance.

The oscillation frequency is modulated with a random source so that the tone energy is spread out. The spread spectrum minimizes the conduction band EMI and the system design can be easier.

The entire application system design can become simpler.

Light Load Mode

In no load or light load condition, major power loss of total power consumption is from switching loss on the MOSFET transistor switching loss, the core loss of the transformer loss and the loss on the external snubber circuit loss become the majority in total power loss. The value of those power loss is proportional to switching actions within a fixed period of time. So reducing number of switching actions leads to reduction of power loss. SD4870 enters Light Load Mode in no load or light load condition. The gate drive output switches only when output DC voltage drops below a present level and the switching frequency reduces. Otherwise the gate drive remains at off state.

Oscillation Frequency Setting

The oscillation frequency is determined by resistor connected between RI and GND. The relationship between the value of this resistor and frequency are shown below

$$f_s = \frac{6500}{R_{RI}} \text{ (kHz)}, \text{ where } R_{RI} \text{ is the value of external resistor and its unit is } K\Omega.$$

Current Sense and LEB

At switching leading edge time, the current spike due to Snubber diode reverse recovery should be chopped off. And this is available through internal LEB (Leading Edge Blanking) circuit. So that the external RC filter circuit on SENSE input is no longer required.

During the blanking period, the PWM comparator and OC comparator are disabled and MOSFET transistor keeps turn-on state if MOSFET turns on. The minimum on time of MOSFET is LEB time.

Gate Drive

GATE pin is connected to external MOSFET's gate for switch control. Too weak the gate drive ability results in more switch loss of MOSFET while too strong gate drive compromises the EMI performance.

A good tradeoff is achieved through the totem pole gate drive design with appropriate output ability and dead time control.

Protection controls

SD4870 offers complete protection functions including cycle-by-cycle over current protection, over load protection, VDD input voltage over voltage and under voltage protection, etc.

Constant output power limit over universal input voltage range is achieved with over current protection threshold line voltage compensation to over current protection threshold.

VDD is supplies by transformer auxiliary winding output. It is clamped when VDD is higher than clamp threshold value. The MOSFET is shut down when VDD drops below UVLO threshold voltage and IC enters power on startup sequence thereafter.

When FB input voltage is higher than over load threshold voltage for more than TD_OL, the MOSFET is shut down and VDD voltage drops. IC restarts when VDD is lower than UVLO threshold voltage.

TYPICAL APPLICATION CIRCUIT

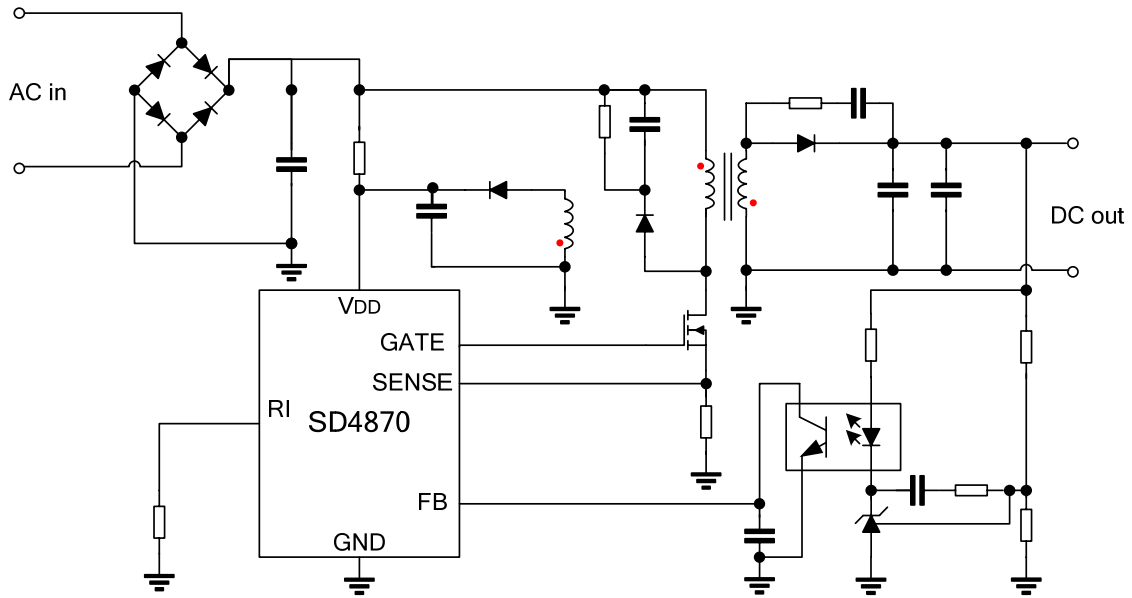

PACKAGE OUTLINE

DIP-8-300-2.54

UNIT: mm

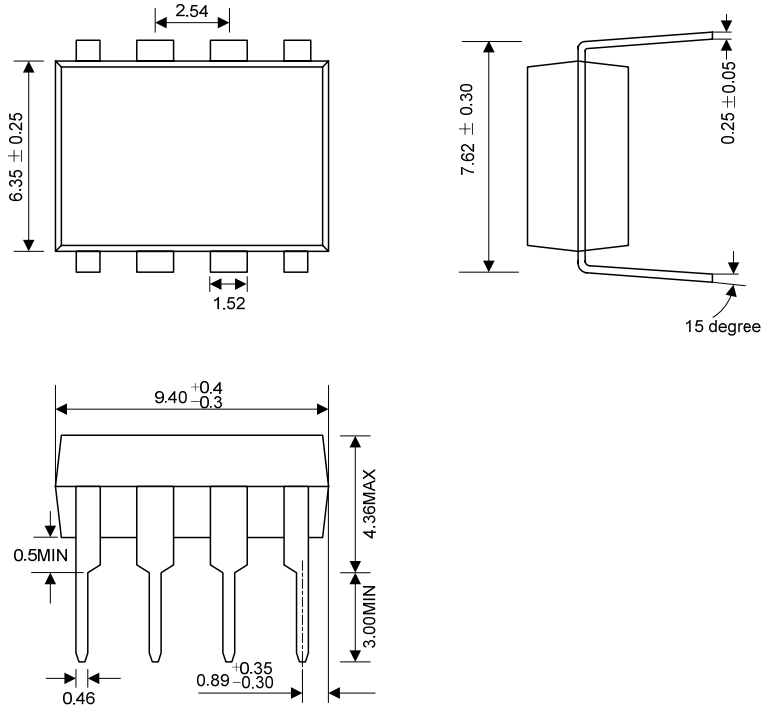

SOP-8-225-1.27

UNIT: mm

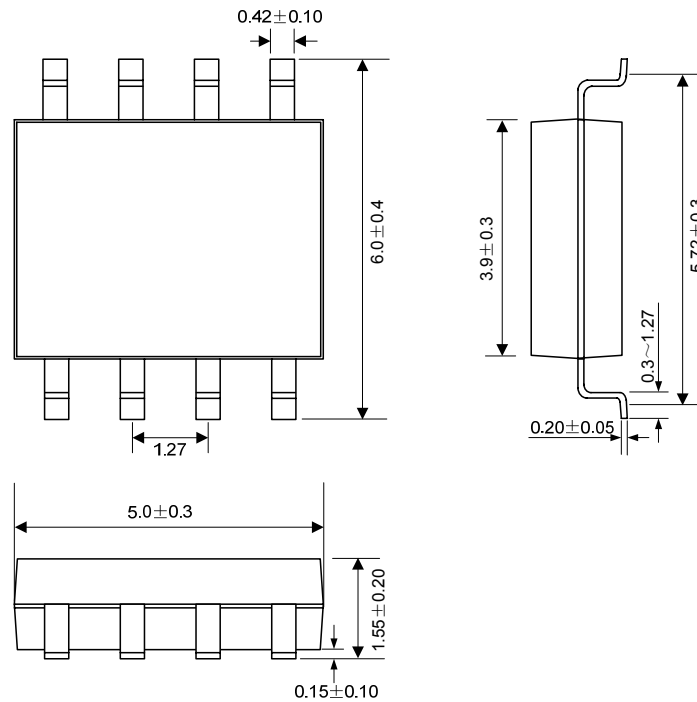

PACKAGE OUTLINE

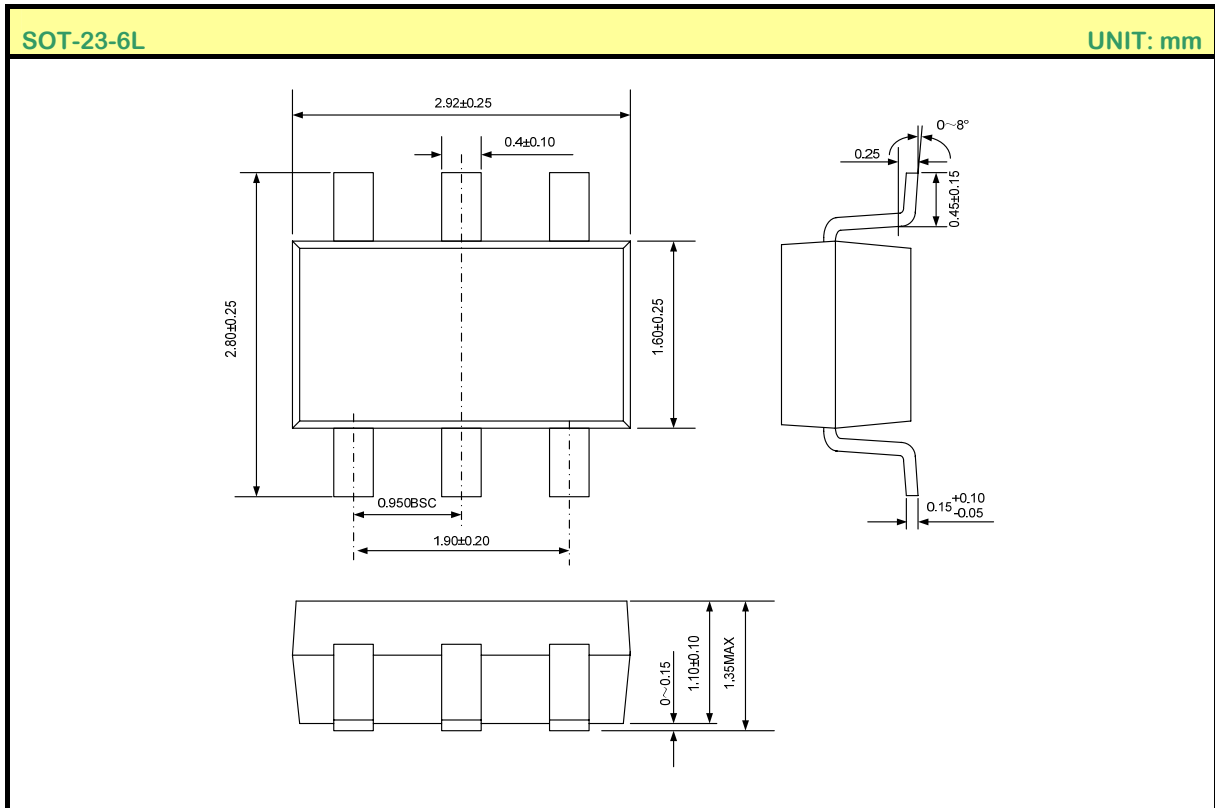

MOS DEVICES OPERATE NOTES:

Electrostatic charges may exist in many things. Please take following preventive measures to prevent effectively the MOS electric circuit as a result of the damage which is caused by discharge:

- The operator must put on wrist strap which should be earthed to against electrostatic.
- Equipment cases should be earthed.
- All tools used during assembly, including soldering tools and solder baths, must be earthed.
- MOS devices should be packed in antistatic/conductive containers for transportation.

Disclaimer :

- Silan reserves the right to make changes to the information herein for the improvement of the design and performance without further notice! Customers should obtain the latest relevant information before placing orders and should verify that such information is complete and current.
- All semiconductor products malfunction or fail with some probability under special conditions. When using Silan products in system design or complete machine manufacturing, it is the responsibility of the buyer to comply with the safety standards strictly and take essential measures to avoid situations in which a malfunction or failure of such Silan products could cause loss of body injury or damage to property.
- Silan will supply the best possible product for customers!



ATTACHMENT

Revision History

Date	REV	Description	Page
2009.08.24	1.0	Original	
2009.09.22	1.0	Modify the" ELECTRICAL CHARACTERISTICS"	
2009.12.23	1.0	Modify the" FEATURES"	
2010.05.27	1.1	Modify the" BLOCK DIAGRAM"	
2010.08.17	1.2	Modify "DESCRIPTIN", "FEATURES"	
2010.12.29	1.3	Modify the template of datasheet	