

20A, 150V SCHOTTKY RECTIFIER

GENERAL DESCRIPTION

SBD20C150T/F is schottky rectifier fabricated in silicon epitaxial planar technology. Typical applications are in switching power supplies and protection circuit etc.

FEATURES

- * Guard ring for Stress Protection
- * High Surge Capacity
- * Low power loss , high efficiency
- * Low forward voltage drop

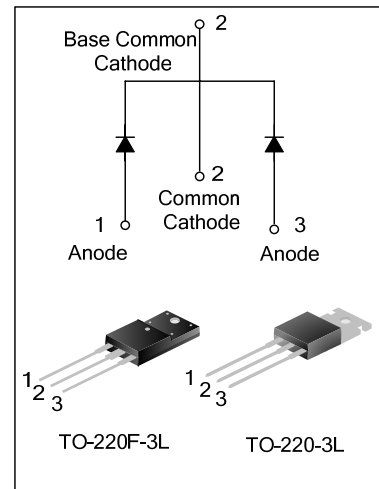

ORDERING SPECIFICATIONS

Part No.	Package	Marking	Material	Packing
SBD20C150T	TO-220-3L	SBD20C150T	Pb free	Tube
SBD20C150F	TO-220F-3L	SBD20C150F	Pb free	Tube

ABSOLUTE MAXIMUM RATINGS (T_c=25°C unless otherwise noted)

Parameter	Symbol	Value	Unit
Maximum Repetitive Peak Reverse Voltage	V _{RRM}	150	V
Average Forward Rectified Current	I _{FAV}	20	A
Peak Forward Surge Current@8.3ms	I _{FSM}	150	A
Operation Junction Temperature	T _J	150	°C
Storage Temperature Range	T _{STG}	-40~150	°C

THERMAL CHARACTERISTICS

Parameter	Symbol	Value	Unit
Thermal Resistance, Junction-to-Case	R _{θJC}	2.0	°C/W

ELECTRICAL CHARACTERISTICS

Parameter	Symbol	Test conditions	Min.	Max.	Unit
Forward Voltage	V _F	I _F =10A (T _C =25°C)	--	0.9	V
		I _F =10A(T _C =125°C)	--	0.75	V
Reverse Current	I _R	V _R =1500V(T _C =25°C)	--	50	μA
		V _R =1500V(T _C =125°C)	--	25	mA

PACKAGE OUTLINE

TO-220-3L(1)

UNIT: mm

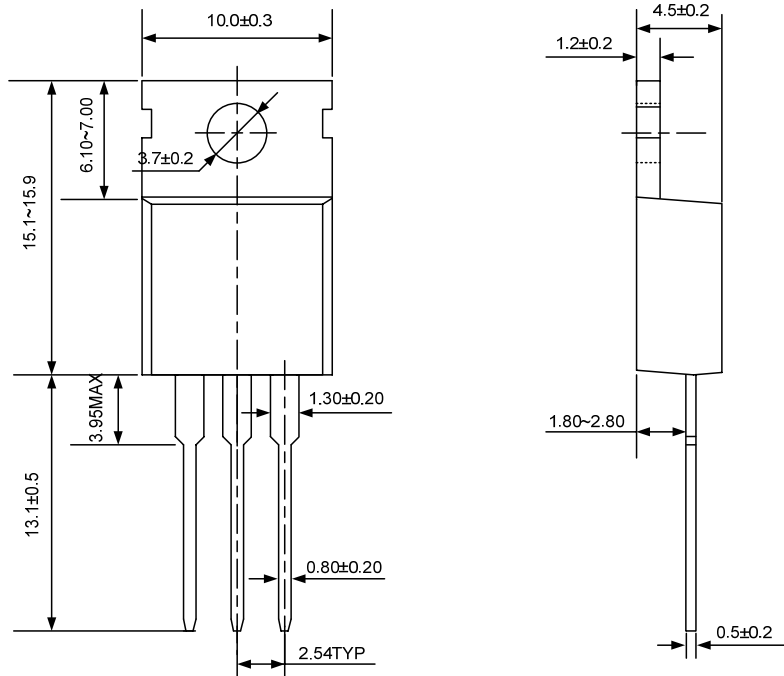

TO-220-3L(2)

UNIT: mm

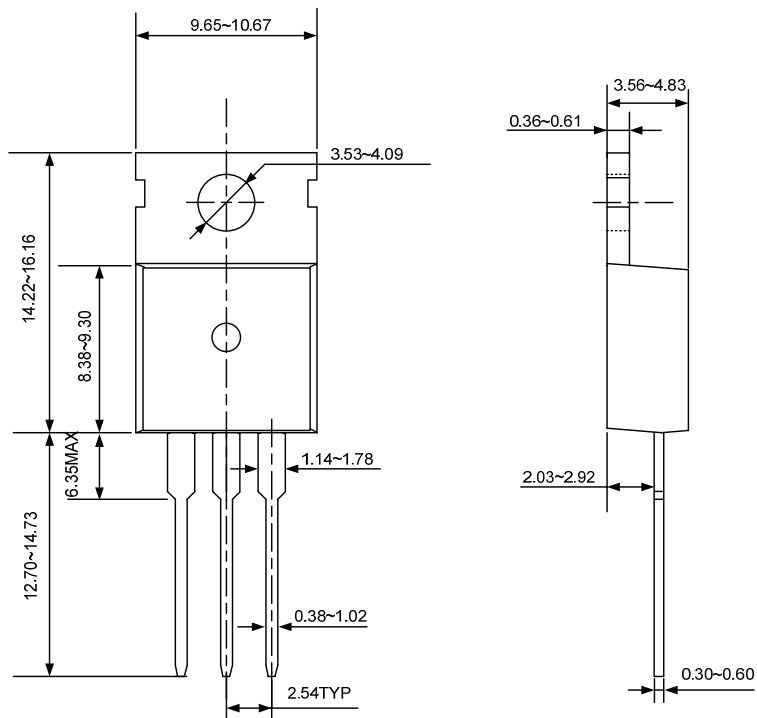

PACKAGE OUTLINE(continued)

TO-220F-3L(1)

UNIT: mm

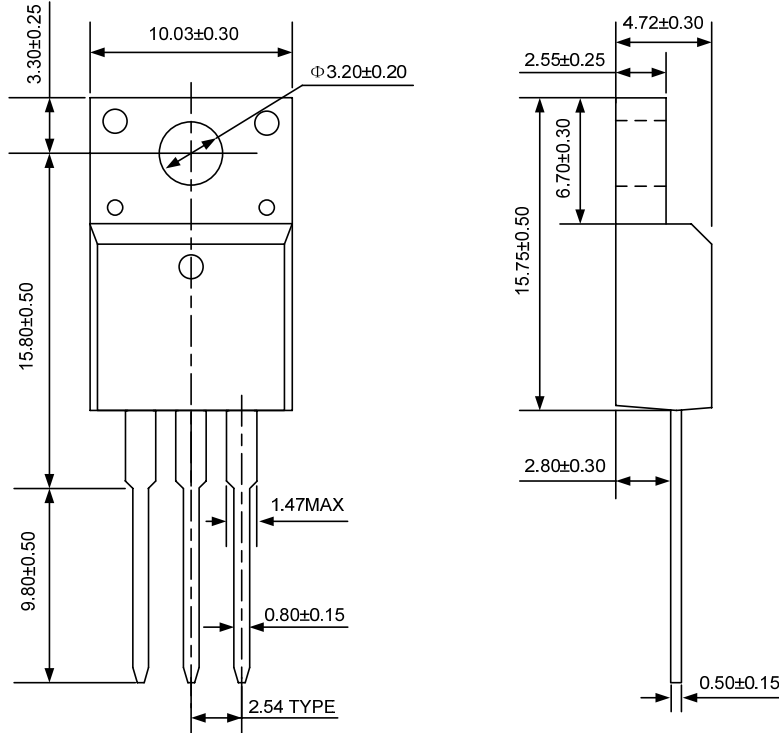

TO-220F-3L(2)

UNIT: mm

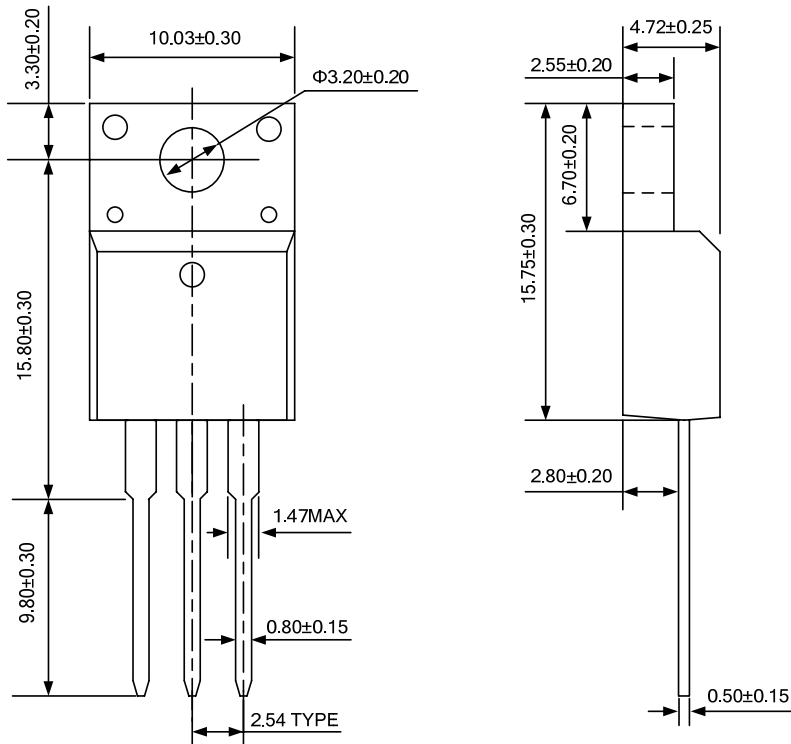



Disclaimer:

- Silan reserves the right to make changes to the information herein for the improvement of the design and performance without further notice! Customers should obtain the latest relevant information before placing orders and should verify that such information is complete and current.
- All semiconductor products malfunction or fail with some probability under special conditions. When using Silan products in system design or complete machine manufacturing, it is the responsibility of the buyer to comply with the safety standards strictly and take essential measures to avoid situations in which a malfunction or failure of such Silan products could cause loss of body injury or damage to property.
- Silan will supply the best possible product for customers!



ATTACHMENT

Revision History

Date	REV	Description	Page
2010.06.09	1.0	Original	
2010.09.02	1.1	Add TO-220-3L, TO-220F-3L package of youyi	
2010.10.22	1.2	Modify the template of datasheet	