

### 1.0 Features

- Primary-side feedback eliminates opto-isolators and simplifies design
- Adaptive multi-mode PWM/PFM control improves efficiency
- Quasi-resonant operation for highest overall efficiency
- **EZ-EMI**® design to easily meet global EMI standards
- Direct drive of low-cost BJT switch
- Dynamic base current control
- Very tight constant voltage and constant current regulation with primary-side-only feedback
- No external compensation components required
- Complies with EPA 2.0 energy-efficiency specifications with ample margin
- Able to meet < 30 mW no load power consumption
- Low start-up current (10  $\mu$ A typical)
- Built-in soft start
- Built-in short circuit protection and output overvoltage protection
- Built-in current sense resistor short protection
- No audible noise over entire operation range

### 2.0 Description

The iW1696 is a high performance AC/DC power supply controller which uses digital control technology to build peak current mode PWM flyback power supplies. The device directly drives a power BJT and operates in quasi-resonant mode to provide high efficiency along with a number of key built-in protection features while minimizing the external component count, simplifying EMI design and lowering the total bill of material cost. The iW1696 removes the need for secondary feedback circuitry while achieving excellent line and load regulation. It also eliminates the need for loop compensation components while maintaining stability overall operating conditions. Pulse-by-pulse waveform analysis allows for a loop response that is much faster than traditional solutions, resulting in improved dynamic load response. The built-in power limit function enables optimized transformer design in universal off-line applications and allows for a wide input voltage range.

The ultra-low start-up power and operating current at light load ensure that the iW1696 is ideal for applications targeting the newest regulatory standards for average efficiency.

### 3.0 Applications

- Low power AC/DC adapter/chargers for cell phones, PDAs, digital still cameras
- Linear AC/DC replacement

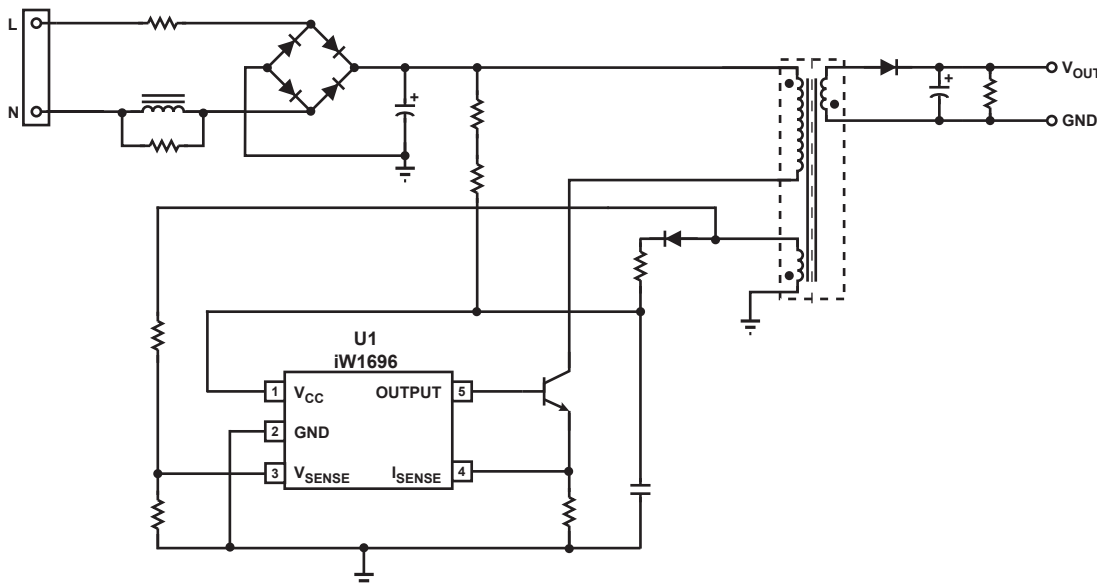
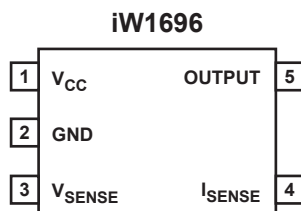

Figure 3.1: iW1696 Typical Application Circuit

### 4.0 Pinout Description



Pin #	Name	Type	Pin Description
1	$V_{CC}$	Power Input	Power supply for control logic.
2	GND	Ground	Ground.
3	$V_{SENSE}$	Analog Input	Auxiliary voltage sense (used for primary regulation).
4	$I_{SENSE}$	Analog Input	Primary current sense. Used for cycle-by-cycle peak current control and limit.
5	OUTPUT	Output	Base drive for BJT.

### 5.0 Absolute Maximum Ratings

Absolute maximum ratings are the parameter values or ranges which can cause permanent damage if exceeded. For maximum safe operating conditions, refer to Electrical Characteristics in Section 6.0.

Parameter	Symbol	Value	Units
DC supply voltage range (pin 1, $I_{CC} = 20\text{mA max}$ )	$V_{CC}$	-0.3 to 18	V
Continuous DC supply current at $V_{CC}$ pin ( $V_{CC} = 15\text{ V}$ )	$I_{CC}$	20	mA
Output (pin 5)		-0.3 to 4.0	V
$V_{SENSE}$ input (pin 3, $I_{V_{sense}} \leq 10\text{ mA}$ )		-0.7 to 4.0	V
$I_{SENSE}$ input (pin 4)		-0.3 to 4.0	V
Maximum junction temperature	$T_{J\text{ MAX}}$	125	°C
Storage temperature	$T_{STG}$	-65 to 150	°C
Lead temperature during IR reflow for $\leq 15$ seconds	$T_{LEAD}$	260	°C
Thermal Resistance Junction-to-Ambient	$\theta_{JA}$	190	°C/W
ESD rating per JEDEC JESD22-A114		2,000	V
Latch-Up test per JEDEC 78		$\pm 100$	mA

## 6.0 Electrical Characteristics

$V_{CC} = 12\text{ V}$ ,  $-40^\circ\text{C} \leq T_A \leq +85^\circ\text{C}$ , unless otherwise specified (Note 1)

Parameter	Symbol	Test Conditions	Min	Typ	Max	Unit
<b><math>V_{SENSE}</math> SECTION (Pin 3)</b>						
Input leakage current	$I_{BVS}$	$V_{SENSE} = 2\text{ V}$			1	$\mu\text{A}$
Nominal voltage threshold	$V_{SENSE(NOM)}$	$T_A = 25^\circ\text{C}$ , negative edge	1.523	1.538	1.553	V
Output OVP threshold -00	$V_{SENSE(MAX)}$	$T_A = 25^\circ\text{C}$ , negative edge		1.834		V
Output OVP threshold -01 (Note 2)	$V_{SENSE(MAX)}$	$T_A = 25^\circ\text{C}$ , negative edge Load = 100 %		1.926		V
Output OVP threshold -03 (Note 2)	$V_{SENSE(MAX)}$	$T_A = 25^\circ\text{C}$ , negative edge Load = 100 %		1.972		V
Output OVP threshold -04 (Note 2)	$V_{SENSE(MAX)}$	$T_A = 25^\circ\text{C}$ , negative edge Load = 100 %		1.880		V
<b><math>I_{SENSE}</math> SECTION (Pin 4)</b>						
Overcurrent threshold	$V_{OCP}$			1.1	1.15	V
$I_{SENSE}$ regulation upper limit (Note 2)	$V_{IPK(HIGH)}$			1.0		V
$I_{SENSE}$ regulation lower limit (Note 2)	$V_{IPK(LOW)}$			0.25		V
Input leakage current	$I_{LK}$	$I_{SENSE} = 1.0\text{ V}$			1	$\mu\text{A}$
<b>OUTPUT SECTION (Pin 5)</b>						
Output low level ON-resistance	$R_{DS(ON)LO}$	$I_{SINK} = 5\text{ mA}$		3	6.0	$\Omega$
Switching frequency (Note 3)	$f_{SW}$	> 50% load		40		kHz
<b><math>V_{CC}</math> SECTION (Pin 1)</b>						
Maximum operating voltage (Note 2)	$V_{CC(MAX)}$				16	V
Start-up threshold	$V_{CC(ST)}$	$V_{CC}$ rising	11	12	13	V
Undervoltage lockout threshold	$V_{CC(UVL)}$	$V_{CC}$ falling	5.2	5.5	5.8	V
Start-up Current	$I_{IN(ST)}$	$V_{CC} = 10\text{ V}$		8	15	$\mu\text{A}$
Quiescent current	$I_{CCQ}$	No $I_b$ current		2.5	3.5	mA
Zener breakdown voltage	$V_{ZB}$	Zener current = 1 mA $T_A = 25^\circ\text{C}$	18	19	20.5	V

### Notes:

Note 1. Adjust  $V_{CC}$  above the start-up threshold ( $V_{CC(ST)}$ ) before setting at 12 V.

Note 2. These parameters are not 100% tested, guaranteed by design and characterization.

Note 3. Operating frequency varies based on the load conditions, see Theory of Operation for more details.

### 7.0 Typical Performance Characteristics

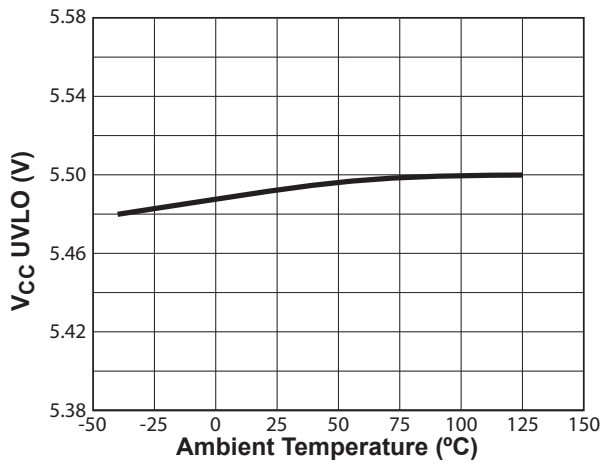

Figure 7.1 : V<sub>CC</sub> UVLO vs. Temperature

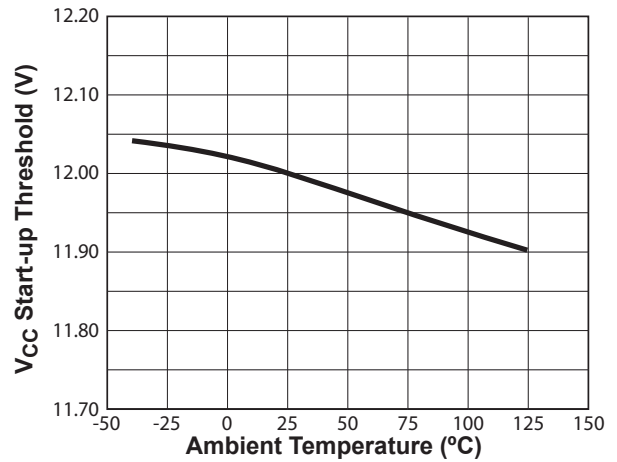

Figure 7.2 : Start-Up Threshold vs. Temperature

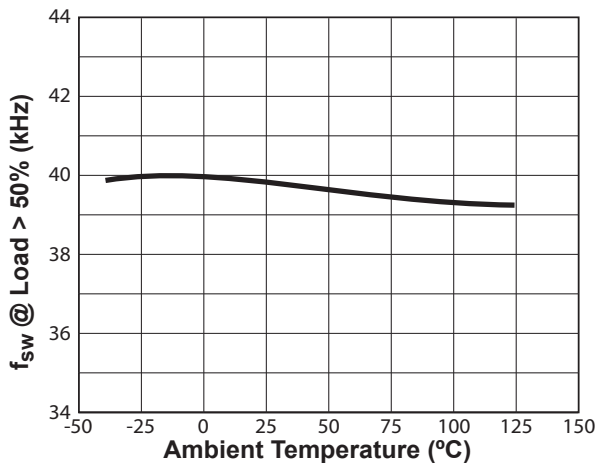

Figure 7.3 : Switching Frequency vs. Temperature<sup>1</sup>

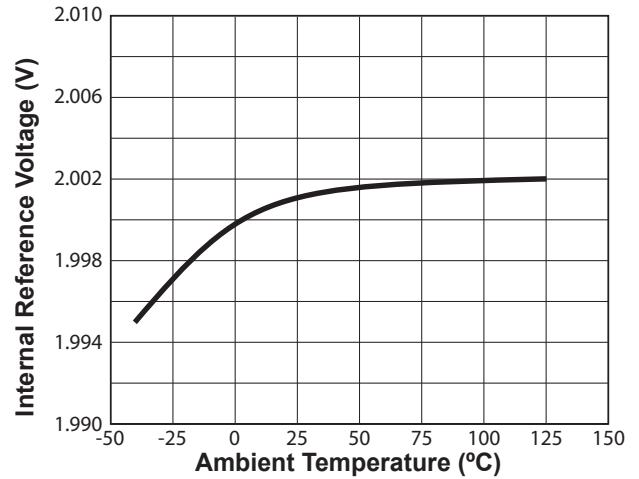

Figure 7.4 : Internal Reference vs. Temperature

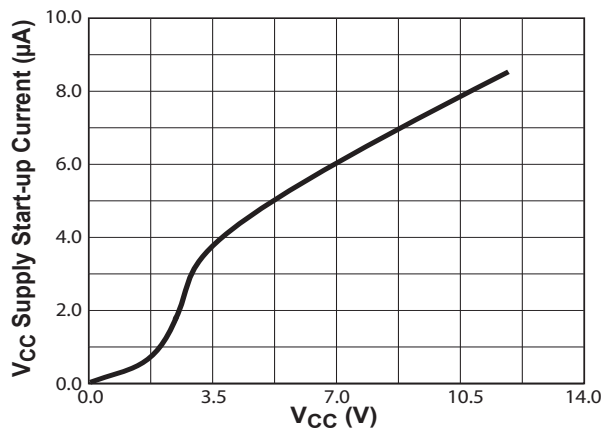

Figure 7.5 : V<sub>CC</sub> vs. V<sub>CC</sub> Supply Start-up Current

#### Notes:

Note 1. Operating frequency varies based on the load conditions, see Theory of Operation for more details.

## 8.0 Functional Block Diagram

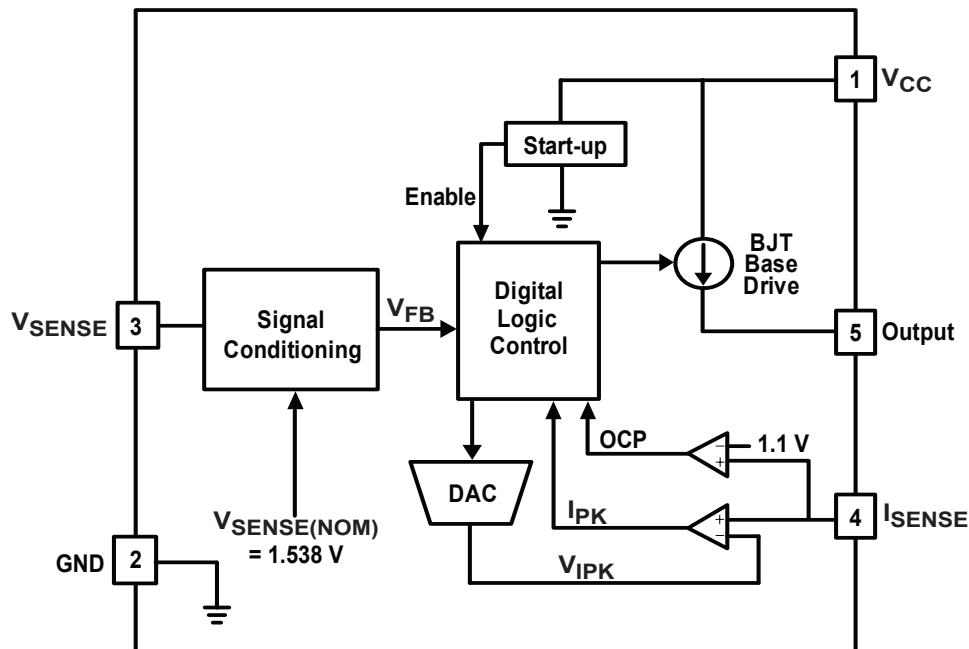

Figure 8.1: iW1696 Functional Block Diagram

## 9.0 Theory of Operation

The iW1696 is a digital controller which uses a new, proprietary primary-side control technology to eliminate the opto-isolated feedback and secondary regulation circuits required in traditional designs. This results in a low-cost solution for low power AC/DC adapters. The core PWM processor uses fixed-frequency Discontinuous Conduction Mode (DCM) operation at higher power levels and switches to variable frequency operation at light loads to maximize efficiency. Furthermore, iWatt's digital control technology enables fast dynamic response, tight output regulation, and full featured circuit protection with primary-side control.

Referring to the block diagram in Figure 8.1, the digital logic control block generates the switching on-time and off-time information based on the output voltage and current feedback signal and provides commands to dynamically control the external BJT base current. The system loop is automatically compensated internally by a digital error amplifier. Adequate system phase margin and gain margin are guaranteed by design and no external analog components are required for loop compensation. The iW1696 uses an advanced digital control algorithm to reduce system design time and increase reliability.

Furthermore, accurate secondary constant-current operation is achieved without the need for any secondary-side sense and control circuits.

The iW1696 uses adaptive multi-mode PWM/PFM control to dynamically change the BJT switching frequency for efficiency, EMI, and power consumption optimization. In addition, it achieves unique BJT quasi-resonant switching to further improve efficiency and reduce EMI. Built-in protection features include overvoltage protection (OVP), output short circuit protection (SCP), over current protection (OCP), single pin fault protection and  $I_{SENSE}$  fault detection.

iWatt's digital control scheme is specifically designed to address the challenges and trade-offs of power conversion design. This innovative technology is ideal for balancing new regulatory requirements for green mode operation with more practical design considerations such as lowest possible cost, smallest size and high performance output control.

### 9.1 Pin Detail

#### Pin 1 – V<sub>CC</sub>

Power supply for the controller during normal operation. The controller will start up when V<sub>CC</sub> reaches 12 V (typical) and will shut-down when the V<sub>CC</sub> voltage is 5.5 V (typical). A decoupling capacitor should be connected between the V<sub>CC</sub> pin and GND.

#### Pin 2 – GND

Ground.

#### Pin 3 – V<sub>SENSE</sub>

Sense signal input from auxiliary winding. This provides the secondary voltage feedback used for output regulation.

#### Pin 4 – I<sub>SENSE</sub>

Primary current sense. Used for cycle-by-cycle peak current control and limit.

#### Pin 5 – OUTPUT

Base drive for the external power BJT switch.

### 9.2 Start-up

Prior to start-up, the V<sub>CC</sub> pin is charged typically through start-up resistors. When V<sub>CC</sub> bypass capacitor is fully charged to a voltage higher than the start-up threshold V<sub>CC(ST)</sub>, the ENABLE signal becomes active to enable the control logic, and the iW1696 commences soft start function. An adaptive soft-start control algorithm is applied at startup state, during which the initial output pulses will be small and gradually get larger until the full pulse width is achieved. The peak current is limited cycle by cycle by the I<sub>PEAK</sub> comparator.

If at any time the V<sub>CC</sub> voltage drops below V<sub>CC(UVL)</sub> threshold then all the digital logic is reset. At this time ENABLE signal becomes low and the V<sub>CC</sub> capacitor is charged up again towards the start-up threshold.

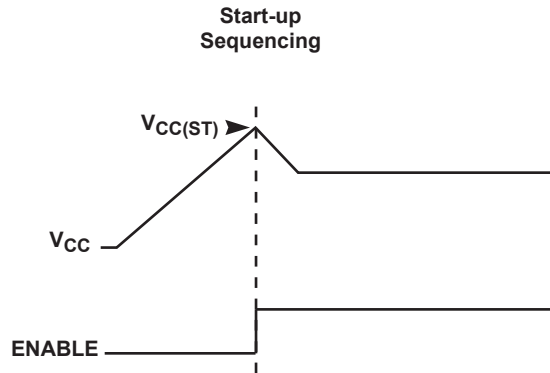

Figure 9.1: Start-up Sequencing Diagram

### 9.3 Understanding Primary Feedback

Figure 9.2 illustrates a simplified flyback converter. When the switch Q1 conducts during t<sub>ON</sub>(t), the current i<sub>g</sub>(t) is directly drawn from rectified sinusoid v<sub>g</sub>(t). The energy E<sub>g</sub>(t) is stored in the magnetizing inductance L<sub>M</sub>. The rectifying diode D1 is reverse biased and the load current I<sub>o</sub> is supplied by the secondary capacitor C<sub>o</sub>. When Q1 turns off, D1 conducts and the stored energy E<sub>g</sub>(t) is delivered to the output.

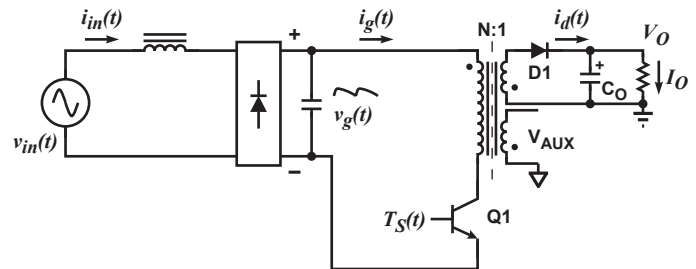

Figure 9.2: Simplified Flyback Converter

In order to tightly regulate the output voltage, the information about the output voltage and load current need to be accurately sensed. In the DCM flyback converter, this information can be read via the auxiliary winding or the primary magnetizing inductance (L<sub>M</sub>). During the Q1 on-time, the load current is supplied from the output filter capacitor C<sub>o</sub>. The voltage across L<sub>M</sub> is v<sub>g</sub>(t), assuming the voltage dropped across Q1 is zero. The current in Q1 ramps up linearly at a rate of:

$$\frac{di_g(t)}{dt} = \frac{v_g(t)}{L_M} \tag{9.1}$$

At the end of on-time, the current has ramped up to:

$$i_{g\_peak}(t) = \frac{v_g(t) \times t_{ON}}{L_M} \quad (9.2)$$

This current represents a stored energy of:

$$E_g = \frac{L_M}{2} \times i_{g\_peak}^2(t) \quad (9.3)$$

When Q1, turns off at  $t_o$ ,  $i_g(t)$  in  $L_M$  forces a reversal of polarities on all windings. Ignoring the commutation-time caused by the leakage inductance  $L_k$  at the instant of turn-off  $t_o$ , the primary current transfers to the secondary at a peak amplitude of:

$$i_d(t) = \frac{N_P}{N_S} \times i_{g\_peak}(t) \quad (9.4)$$

Assuming the secondary winding is master, and the auxiliary winding is slave,

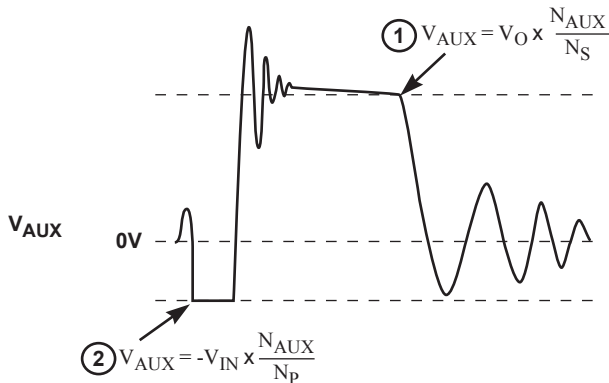

Figure 9.3: Auxiliary Voltage Waveforms

The auxiliary voltage is given by:

$$V_{AUX} = \frac{N_{AUX}}{N_S} (V_O + \Delta V) \quad (9.5)$$

and reflects the output voltage as shown in Figure 9.3.

The voltage at the load differs from the secondary voltage by a diode drop and IR losses. Thus, if the secondary voltage is always read at a constant secondary current, the difference between the output voltage and the secondary voltage will be a fixed  $\Delta V$ . Furthermore, if the voltage can be read when the secondary current is small,  $\Delta V$  will also be small. With the iW1696,  $\Delta V$  can be ignored.

The real-time waveform analyzer in the iW1696 reads this information cycle by cycle. The part then generates a

feedback voltage  $V_{FB}$ . The  $V_{FB}$  signal precisely represents the output voltage under most conditions and is used to regulate the output voltage.

### 9.4 Constant Voltage Operation

After soft-start has been completed, the digital control block measures the output conditions. It determines output power levels and adjusts the control system according to a light load or heavy load. If this is in the normal range, the device operates in the Constant Voltage (CV) mode, and changes the pulse width ( $T_{ON}$ ) and off time ( $T_{OFF}$ ) in order to meet the output voltage regulation requirements.

If no voltage is detected on  $V_{SENSE}$  it is assumed that the auxiliary winding of the transformer is either open or shorted and the iW1696 shuts down.

### 9.5 Constant Current Operation

The constant current (CC mode) is useful in battery charging applications. During this mode of operation the iW1696 will regulate the output current at a constant level regardless of the output voltage, while avoiding continuous conduction mode.

To achieve this regulation the iW1696 senses the load current indirectly through the primary current. The primary current is detected by the  $I_{SENSE}$  pin through a resistor from the BJT emitter to ground.

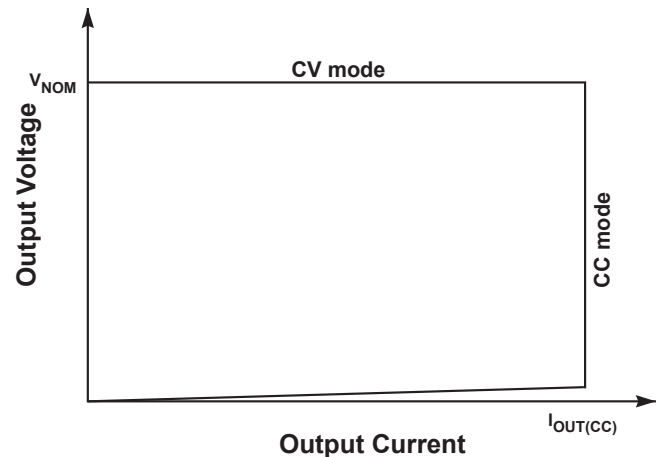

Figure 9.4: Power Envelope

### 9.6 Multi-Mode PWM/PFM Control and Quasi-Resonant Switching

The iW1696 uses an adaptive multi-mode PWM /PFM control to dramatically improve the light-load efficiency and thus the overall average efficiency.

During the constant voltage (CV) operation, the iW1696 normally operates in a pulse-width-modulation (PWM) mode during heavy load conditions. In the PWM mode, the switching frequency keeps around constant. As the output load  $I_{OUT}$  is reduced, the on-time  $t_{ON}$  is decreased, and the controller adaptively transitions to a pulse-frequency-modulation (PFM) mode. During the PFM mode, the BJT is turned on for a set duration under a given instantaneous rectified AC input voltage, but its off time is modulated by the load current. With a decreasing load current, the off time increases and thus the switching frequency decreases.

As the load current is further reduced, the iW1696 transitions to a deep PFM mode (DPFM) which reduces the switching frequency to a very low level.

While operating in the adaptive multi-mode PWM/PFM control, iW1696 also incorporates a unique quasi-resonant switching in both CV and CC operations. Together these innovative digital control architecture and algorithms enable iW1696 to achieve highest overall efficiency and lowest EMI.

### 9.7 Variable Frequency Operation Mode

At each of the switching cycles, the falling edge of  $V_{SENSE}$  will be checked. If the falling edge of  $V_{SENSE}$  is not detected, the off-time will be extended until the falling edge of  $V_{SENSE}$  is detected. The maximum allowed transformer reset time is 75  $\mu$ s. When the transformer reset time reaches 75  $\mu$ s, the iW1696 immediately shuts off.

### 9.8 Internal Loop Compensation

The iW1696 incorporates an internal Digital Error Amplifier with no requirement for external loop compensation. For a typical power supply design, the loop stability is guaranteed to provide at least 45 degrees of phase margin and -20 dB of gain margin.

### 9.9 Voltage Protection Features

The secondary maximum output DC voltage is limited by the iW1696. When the  $V_{SENSE}$  signal exceeds the output

OVP threshold at point 1 indicated in figure 9.3 the iW1696 immediately shuts down.

The iW1696 protects against input line undervoltage by setting a maximum  $T_{ON}$  time. Since output power is proportional to the squared  $V_{IN}T_{ON}$  product then for a given output power as  $V_{IN}$  decreases the  $T_{ON}$  will increase. Thus by knowing when the maximum  $T_{ON}$  time occurs the iW1696 detects that the minimum  $V_{IN}$  is reached, and shuts down. The maximum  $t_{ON}$  limit is set to 22  $\mu$ s. Also, the iW1696 monitors the voltage on the  $V_{CC}$  pin and when the voltage on this pin is below UVLO threshold the IC shuts down immediately. The output voltage is monitored through the  $V_{SENSE}$  pin. When the overvoltage threshold is exceeded, the iW1696 will shut down immediately.

When any of these faults are met the IC remains biased to discharge the  $V_{CC}$  supply. Once  $V_{CC}$  drops below UVLO threshold, the controller resets itself and then initiates a new soft-start cycle. The controller continues attempting start-up until the fault condition is removed.

### 9.10 PCL, OCP and SRS Protection

Peak-current limit (PCL), over-current protection (OCP) and sense-resistor short protection (SRSP) are features built-in to the iW1696. With the  $I_{SENSE}$  pin the iW1696 is able to monitor the peak primary current. This allows for cycle by cycle peak current control and limit. When the primary peak current multiplied by the  $I_{SENSE}$  resistor is greater than 1.1 V over current (OCP) is detected and the IC will immediately turn off the base driver until the next cycle. The output driver will send out a switching pulse in the next cycle, and the switching pulse will continue if the OCP threshold is not reached; or, the switching pulse will turn off again if the OCP threshold is reached. If the OCP occurs for several consecutive switching cycles, the iW1696 shuts down.

If the  $I_{SENSE}$  resistor is shorted there is a potential danger of the over current condition not being detected. Thus, the IC is designed to detect this sense-resistor-short fault after startup and shut down immediately. The  $V_{CC}$  will be discharged since the IC remains biased. Once  $V_{CC}$  drops below the UVLO threshold, the controller resets itself and then initiates a new soft-start cycle. The controller continues attempting to startup, but does not fully startup until the fault condition is removed.

### 9.11 Dynamic Base Current Control

One important feature of the iW1696 is that it directly drives a BJT switching device with dynamic base current control to optimize performance. The BJT base current ranges from

10 mA to 31 mA, and is dynamically controlled according to the power supply load change. The higher the output power, the higher the base current. Specifically, the base current is related to  $V_{IPK}$ , as shown in Figure 9.5.

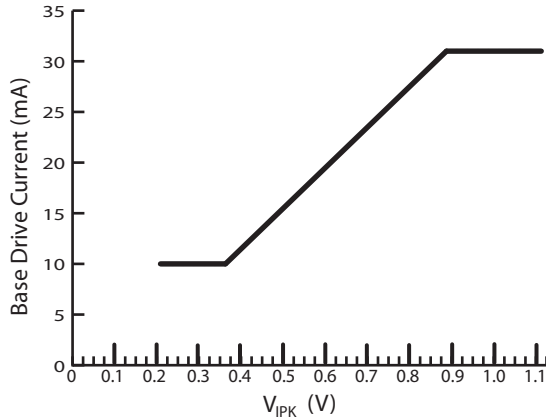

Figure 9.5: Base Drive Current vs.  $V_{IPK}$

### 9.12 Cable Drop Compensation

The iW1696 incorporates an innovative method to compensate for any IR drop in the secondary circuitry including cable and cable connector. A 2.5 W adapter with 5 V DC output has 3% deviation at 0.5 A load current due to the drop across a 24 AWG, 1.8 meter DC cable without cable compensation. The iW1696 compensates for this voltage drop by providing a voltage offset to the feedback signal based on the amount of load current detected.

To calculate the amount of cable compensation needed, take the resistance of the cable and connector and multiply by the maximum output current.

### 10.0 Physical Dimensions

#### 5-Lead SOT Package

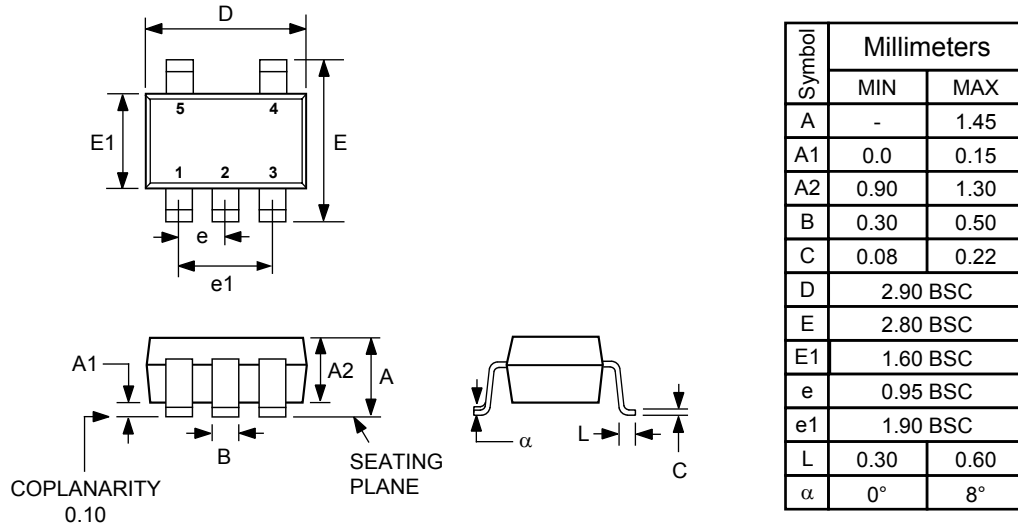

Figure 10.1: Physical dimensions, 5-lead SOT-23 package

Compliant to JEDEC Standard MO178

Controlling dimensions are in millimeters

This package is RoHS compliant, and conform to Halide free limits.

Soldering Temperature Resistance:

[a] Package is IPC/JEDEC Std 020D Moisture Sensitivity Level 1

[b] Package exceeds JEDEC Std No. 22-A111 for Solder Immersion resistance; packages can withstand 10 s immersion @ < 270 °C

Dimension D does not include mold flash, protrusions or gate burrs. Mold flash, protrusions or gate burrs shall not exceed 0.25 mm per end. Dimension E1 does not include interlead flash or protrusion. Interlead flash or protrusion shall not exceed 0.25 mm per side. D and E1 dimensions are determined at datum H.

The package top may be smaller than the package bottom. Dimension D and E1 are determined at the outermost extremes of the plastic body exclusive of mold flash, tie bar burrs, gate burrs and interlead flash, but including any mismatch between the top and bottom of the plastic body. D and E1 dimensions are determined at datum H.

### 11.0 Ordering Information

Part Number	Options	Package	Description
iW1696-00	Cable Comp = 0 mV	SOT-23	Tape & Reel <sup>1</sup>
iW1696-01	Cable Comp = 300 mV	SOT-23	Tape & Reel <sup>1</sup>
iW1696-03	Cable Comp = 450 mV	SOT-23	Tape & Reel <sup>1</sup>
iW1696-04	Cable Comp = 150 mV	SOT-23	Tape & Reel <sup>1</sup>

Note 1: Tape & Reel packing quantity is 3,000 per reel. Minimum ordering quantity is 3,000.

Note 2: This product is RoHS compliant and Halide free.

# iW1696

## Low-Power Off-line Digital Green-Mode PWM Controller



### About iWatt

iWatt Inc. is a fabless semiconductor company that develops intelligent power management ICs for computer, communication, and consumer markets. The company's patented *pulseTrain*™ technology, the industry's first truly digital approach to power system regulation, is revolutionizing power supply design.

### Trademark Information

© 2009 iWatt, Inc. All rights reserved. iWatt, the iW light bulb, *EZ-EMI* and *pulseTrain* are trademarks of iWatt, Inc. All other trademarks and registered trademarks are the property of their respective companies.

### Contact Information

**Web:** <http://www.iwatt.com>

**E-mail:** [info@iwatt.com](mailto:info@iwatt.com)

**Phone:** 408-374-4200

**Fax:** 408-341-0455

**iWatt Inc.**

101 Albright Way

Los Gatos CA 95032-1827

### Disclaimer

iWatt reserves the right to make changes to its products and to discontinue products without notice. The applications information, schematic diagrams, and other reference information included herein is provided as a design aid only and are therefore provided as-is. iWatt makes no warranties with respect to this information and disclaims any implied warranties of merchantability or non-infringement of third-party intellectual property rights.

Certain applications using semiconductor products may involve potential risks of death, personal injury, or severe property or environmental damage ("Critical Applications").

IWATT SEMICONDUCTOR PRODUCTS ARE NOT DESIGNED, INTENDED, AUTHORIZED, OR WARRANTED TO BE SUITABLE FOR USE IN LIFE-SUPPORT APPLICATIONS, DEVICES OR SYSTEMS, OR OTHER CRITICAL APPLICATIONS.

Inclusion of iWatt products in critical applications is understood to be fully at the risk of the customer. Questions concerning potential risk applications should be directed to iWatt, Inc.

iWatt semiconductors are typically used in power supplies in which high voltages are present during operation. High-voltage safety precautions should be observed in design and operation to minimize the chance of injury.